

# 1. Housing components (カバー関係)

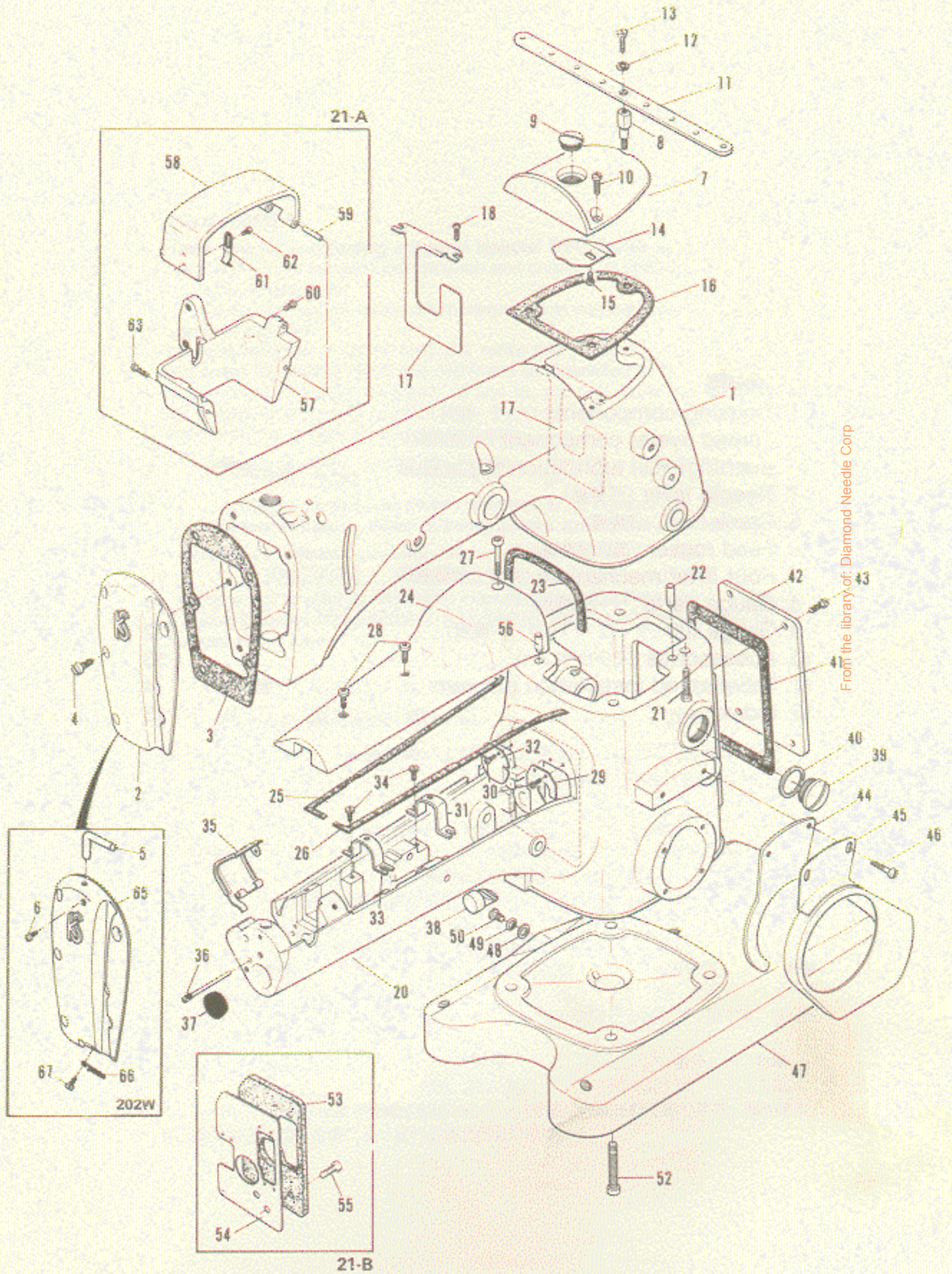

From the library of: Diamond Needle Corp



Ref. No.	Part No.	Part Name	Q'ty	Ref. No.	Part No.	Part Name	Q'ty
1	22-201	DVC-200 arm	1	35	21-451	Cylinder hinged cover	1
2	21-326	Head cover	1	36	84-531	Hinge screw	1
3	23-214	Gasket	1	37	23-171	Plug	1
4	84-566	Screw	5	38	39-214	Oil gauge	1
5	45-216	Pull-off wire	1	39	87-812	Screw	1
6	84-162	Screw	1	40	23-298	Gasket	1
7	21-205	Crank chamber oil cover	1	41	23-246	Gasket	1
8	41-317	Screw	1	42	21-446	Cover	1
9	87-511	Screw	1	43	84-571	Screw	4
10	84-566	Screw	2	44	21-407	Cloth guard	1
11	41-316	Eyelet-support	1	45	21-406	Belt guard	1
12	75-458	Washer	1	46	84-571	Screw	2
13	84-761	Screw	1	47	22-221	Cylinder base	1
14	35-160	Oil drip plate	1	48	23-300	Gasket	1
15	84-571	Screw	1	49	23-189	Gasket	1
16	23-204	Gasket	1	50	85-521	Screw	1
17	39-124	Baffle plate	1	51			
18	84-161	Screw	1	52	87-661	Screw	4
19	84-162			53	39-148	Fence felt	1
20	22-212	Cylinder	1	54	39-141	Baffle plate	1
21	87-661	Screw	4	55	84-571	Screw	1
22	71-482	Pin	1	56	71-261	Taper pin	1
23	23-232	Gasket	1	57	21-147	Case for take-up	1
24	21-516	Cylinder cover	1	58	21-146	Cover	1
25	23-227	Gasket (left)	1	59	71-246	Pin	1
26	23-226	Gasket (right)	1	60	84-163	Screw	1
27	84-577	Screw	1	61	79-506	Spring	1
28	84-580	Screw	2	62	84-161	Screw	2
29	39-172	Fence B	1	63	84-571	Screw	2
30	93-701	Rivet	4	64			
31	25-202	Support for cylinder cover rear	1	65	21-222	Head cover	1
32	39-171	Fence A	1	66	45-202	Needle thread eyelet	1
33	25-203	Support for cylinder cover front	1	67	84-361	Screw	1
34	84-664	Screw	4				
21-A	20-121	Case for take-up cover ass'y					
21-B	30-921	Baffle plate ass'y					

From the library of: Diamond Needle Corp



## 2. Thread eyelet component (糸道関係)

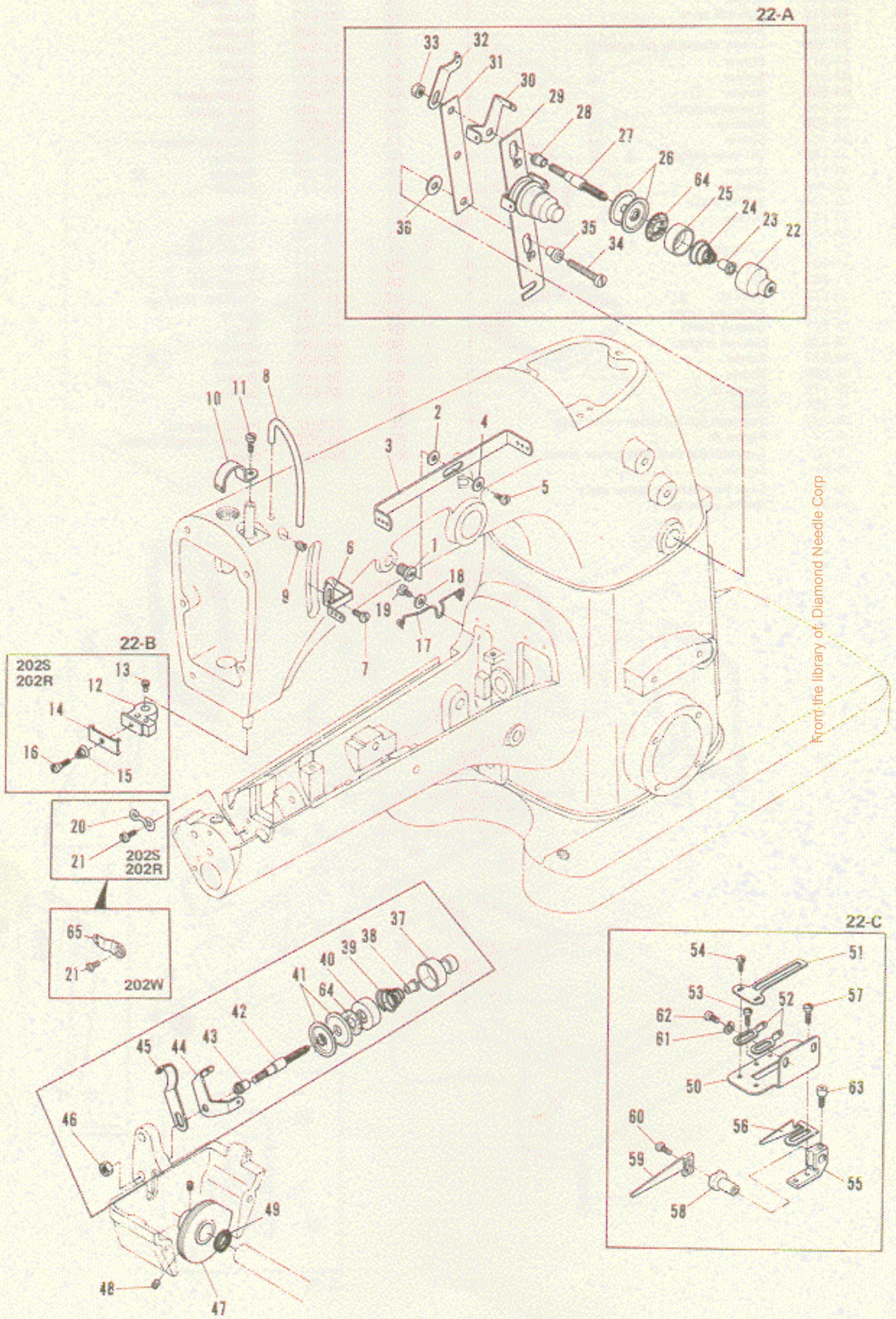

From the library of: Diamond Needle Corp



Ref. No.	Part No.	Part Name	Q'ty	Ref. No.	Part No.	Part Name	Q'ty
1	85-531	Screw	1	34	84-764	Screw	1
2	75-456	Washer	1	35	41-132	Tension post collar B	1
3	45-110	Thread eyelet	1	36	75-381	Washer	1
4	75-453	Washer	1	37	41-101	Tension regulating	1
5	84-571	Screw	1	38	41-105	Tension disc ratchet	1
6	45-118	Needle lever thread eyelet	1	39	41-702	Looper thread tension spring	1
7	84-363	Screw	1	40	41-107	Tension disc cover	1
8	45-226	Needle thread leading wire	1	41	41-111	Tension disc	2
9	84-521	Screw	1	42	41-172	Tension post	1
10	45-140	Needle bar thread eyelet	1	43	41-131	Tension post collar A	1
11	84-361	Screw	1	44	41-115	Tension post thread eyelet	1
12	41-303	Tension nipper plate	1	45	41-117	Lead in thread eyelet	1
13	84-364	Screw	1	46	86-411	Nut	1
14	45-142	Tension nipper	1	47	49-135	Looper thread take-up double disc	1
15	41-721	Tension nipper spring	1	48	84-711	Screw	2
16	84-171	Screw	1	49	23-197	φ12.5 O-ring	1
17	47-211	Thread eyelet (rear)	1	50	43-401	Take-up shield	1
18	75-468	Washer	1	51	43-102	Cast-off plate	1
19	84-575	Screw	1	52	43-402	Eyelet	2
20	47-212	Thread eyelet (front)	1	53	85-621	Screw	2
21	84-361	Screw	1	54	84-161	Screw	2
22	41-101	Tension regulating	2	55	43-111	Retainer support bracket	1
23	41-105	Tension disc ratchet	2	56	43-106	Cast-off	1
24	41-701	Needle thread tension spring	2	57	84-162	Screw	2
25	41-107	Tension disc cover	2	58	43-112	Pin for thread retainer	1
26	41-111	Tension disc cover	4	59	43-303	Looper thread retainer	1
27	41-172	Tension post	2	60	84-374	Screw	1
28	41-131	Tension post collar A	2	61	75-453	Washer	2
29	41-112	Tension post holder	1	62	84-571	Screw	2
30	41-115	Tension post thread eyelet	2	63	84-363	Screw	1
31	41-122	Tension post holder	1	64	23-324	Felt	3
32	41-117	Lead in thread eyelet	2	65	47-207	Looper thread eyelet	1
33	86-411	Nut	2				
22-A	40-120	Thread tension ass'y					
22-B	40-531	Tension nipper ass'y					
22-C	40-321	Cast-off support plate ass'y					
22-D	40-101	Looper thread tension ass'y					



### 3. Bushings•Oil lubrication apparatus (ブッシュ、給油関係)

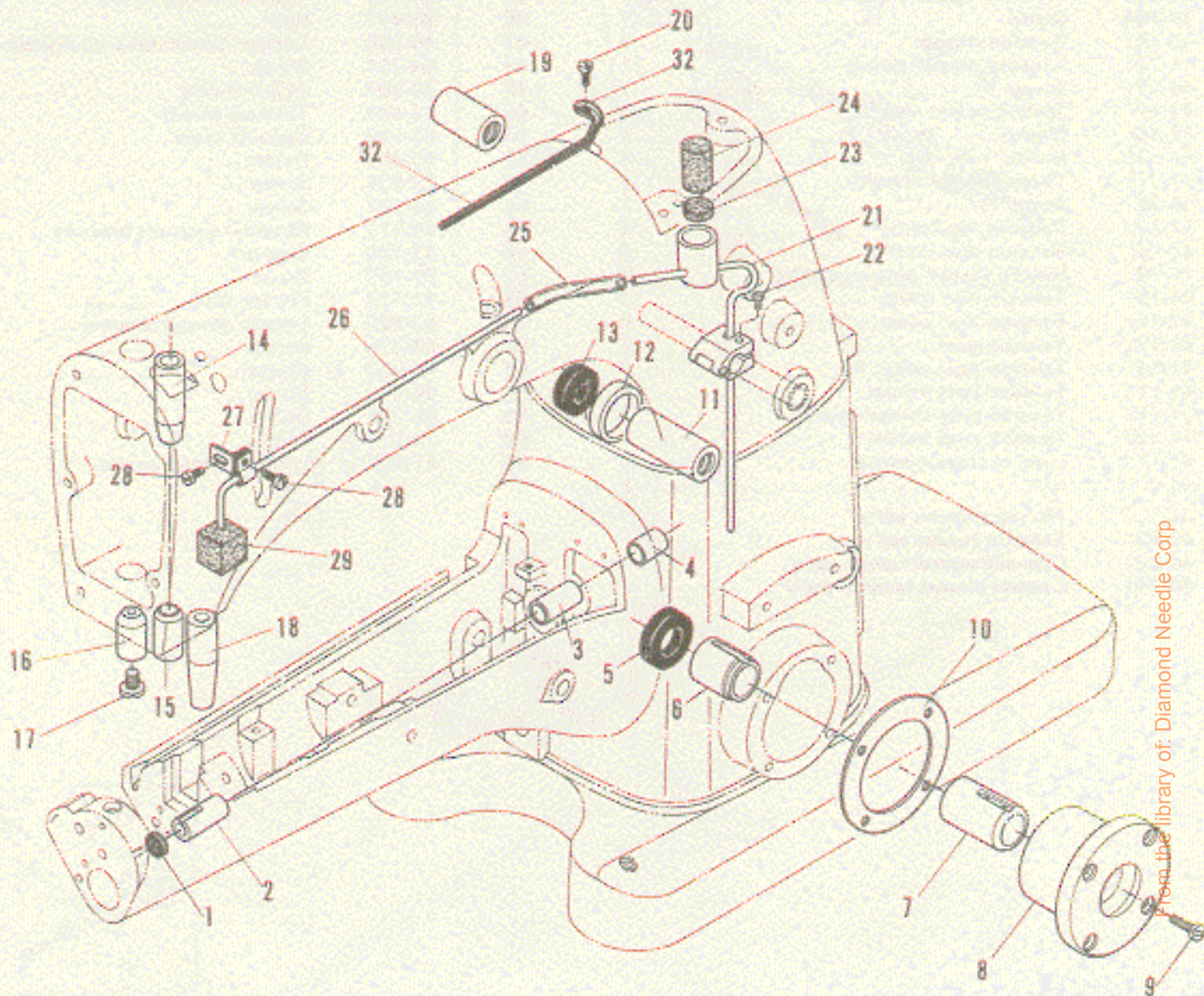

From the library of: Diamond Needle Corp

Ref. No.	Part No.	Part Name	Q'ty	Ref. No.	Part No.	Part Name	Q'ty
1	94-236	Gasket	1	17	85-522	Screw	1
2	81-156	Bushing (A) for looper bar	1	18	81-161	Bushing for presser bar	1
3	81-157	Bushing (B) for looper bar	1	19	81-255	Presser foot lifter lever bushing	1
4	81-158	Bushing (C) for looper bar	1	20	84-162	Screw	1
5	94-211	Gasket	1	21	35-151	Siphon	1
6	81-119	Crankshaft bushing	1	22	84-568	Screw	1
7	81-116	Bushing	1	23	35-154	Siphon cup disc felt	1
8	69-304	Flange	1	24	35-155	Felt plug	1
9	84-566	Screw	4	25	35-156	Oil tube connection	1
10	23-242	Gasket	1	26	35-157	Oil siphon tube	1
11	81-145	Bushing	1	27	35-161	Oil tube clamp	1
12	81-405	Bushing	1	28	84-361	Screw	2
13	94-221	Gasket	1	29	23-353	Felt lint filter	1
14	81-185	Needle bar bushing (upper)	1	30			
15	81-184	Needle bar bushing (lower)	1	31			
16	81-152	Bushing for presser guide bar	1	32	35-268	Needle lever joint ball oiler	1



# 4. Needle lever (弓機構)

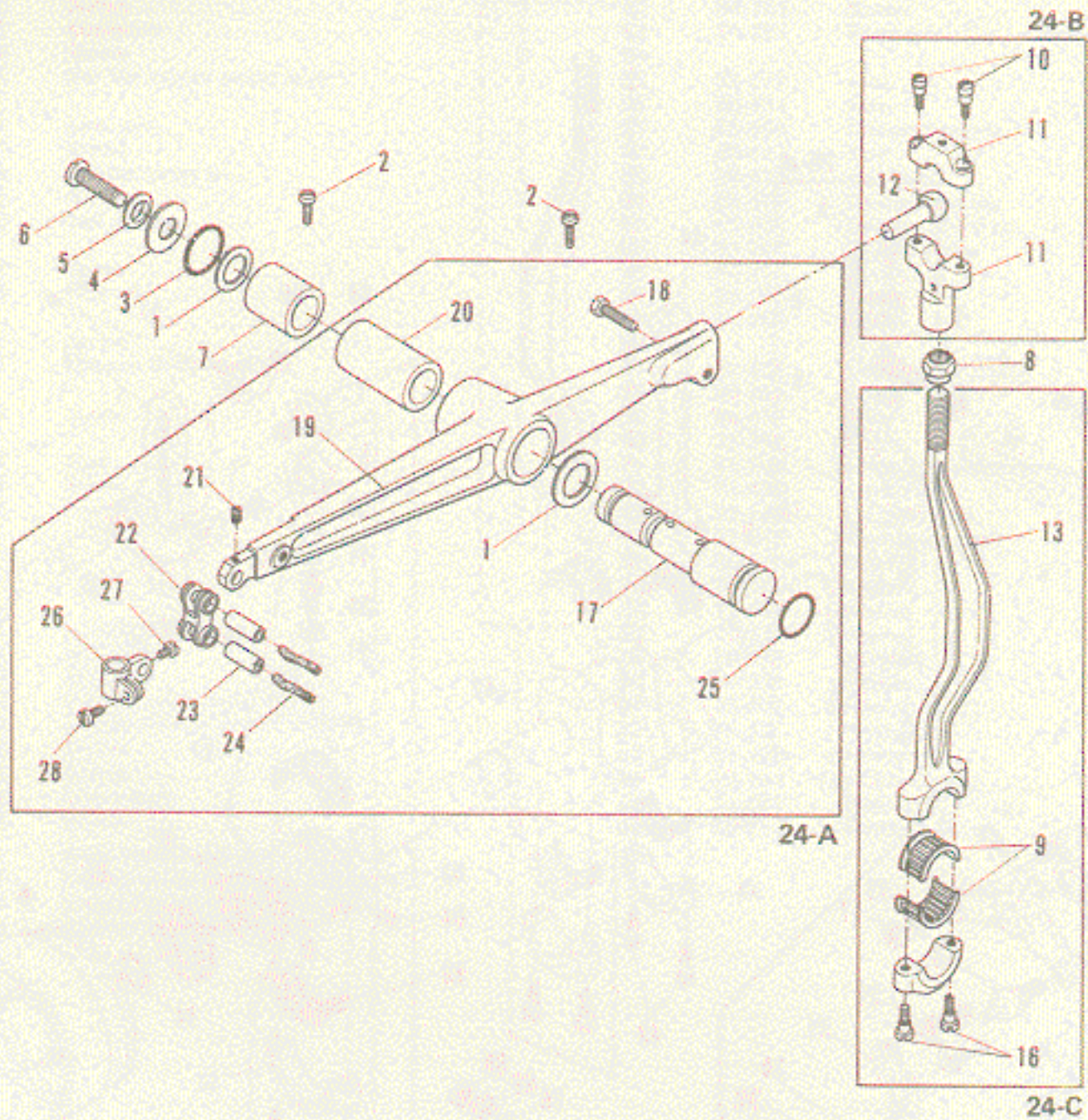

From the library of: Diamond Needle Corp

Ref. No.	Part No.	Part Name	Q'ty	Ref. No.	Part No.	Part Name	Q'ty
1	75-332	Washer	2	15	84-568	Screw	2
2	84-764	Screw	2	16	71-932	Needle lever stud	1
3	23-195	Oil seal ring	1	17	85-211	Screw	1
4	39-107	Washer	1	18	69-103	Needle lever	1
5	23-260	Gasket	1	19	81-113	Needle lever bushing	1
6	85-182	Screw	1	20	84-366	Screw	1
7	81-411	Needle lever shaft stop collar	1	21	66-111	Needle bar link	1
8	86-742	Nut	1	22	71-432	Link pin	2
9	91-306	Needle bearing	1	23	23-341	Felt	2
10	84-567	Screw	2	24	23-195	Oil seal ring	1
11	63-711	Needle lever ball joint bearing	1	25	73-113	Needle bar connection	1
12	61-726	Ball	1	26	84-365	Screw	1
13	69-351	Needle lever connection	1	27	84-572	Screw	1
14				28			
24-A	60-921	Needle lever ass'y					
24-B	60-326	Needle lever driving ball joint ass'y					
24-C	60-320	Needle lever rod ass'y					



# 5. Crank (クランク機構)

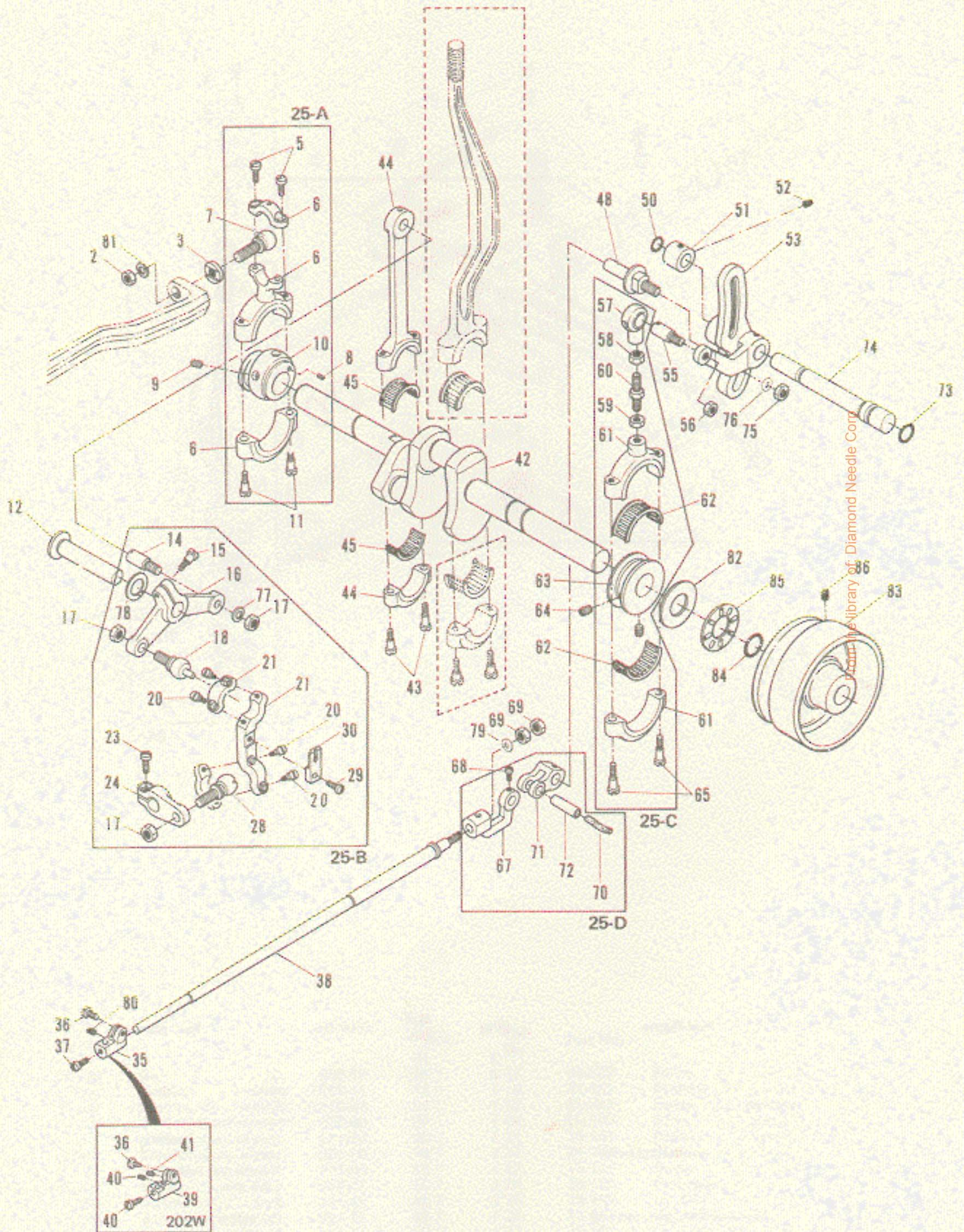



Ref. No.	Part No.	Part Name	Q'ty	Ref. No.	Part No.	Part Name	Q'ty
1				44	63-361	Looper drive lever connection	1
2	86-411	Nut	1	45	91-303	Needle roller	1
3	51-201	Washer	1	46			
4				47			
5	84-572	Screw	2	48	51-214	Stud for looper avoid link	1
6	63-521	Feed rocker connecting rod	1	49			
7	61-831	Feed rocker ball joint	1	50	23-188	O-ring	1
8	84-112	Screw	1	51	75-132	Collar	1
9	84-718	Screw	2	52	84-761	Screw	1
10	61-521	Eccentric	1	53	51-221	Feed drive and looper avoid	1
11	84-568	Screw	2	54			
12	71-671	Bar for looper avoid lever	1	55	51-211	Link pin	1
13				56	86-411	Nut	1
14	51-211	Link pin	1	57	63-401	Connecting rod	1
15	84-761	Screw	1	58	86-413	Nut	1
16	67-156	Looper drive lever	1	59	86-415	Nut (left)	1
17	86-413	Nut	3	60	65-504	Connecting bar	1
18	61-836	Ball screw	1	61	63-321	Looper avoid connection	1
19				62	91-301	Needle roller	1
20	84-367	Screw	4	63	61-211	Eccentric	1
21	63-805	Rod	1	64	84-718	Screw	2
22				65	84-568	Screw	2
23	84-763	Screw	1	66			
24	67-157	Looper drive lever	1	67	51-225	Looper avoid link	1
25				68	84-365	Screw	1
26	84-512	Screw	1	69	86-411	Nut	2
27				70	23-341	Felt	1
28	61-837	Rod	1	71	51-224	Looper avoid drive link	1
29	84-363	Screw	1	72	71-432	Link pin	1
30	69-125	Guide fork	1	73	23-190	Oil read ring	1
31				74	51-213	Base lever shaft	1
32				75	86-411	Nut	1
33				76	75-452	Washer	1
34				77	75-453	Washer	1
35	19-321	Looper holder	1	78	75-372	Washer	1
36	84-564	Screw	1	79	75-453	Washer	1
37	84-616	Screw	1	80	84-521	Screw	1
38	71-547	Looper rock shaft	1	81	75-401	Washer	1
39	19-322	Looper holder 5/16" (202W)	1	82	75-321	Washer	1
40	84-616	Screw	2	83	69-208	Pulley	1
41	84-521	Screw	1	84	23-197	φ12.5 O-ring	1
42	71-824	Crankshaft	1	85	92-231	Bearing	1
43	84-568	Screw	2	86	85-114	Screw	2
25-A	60-321	Feed rocker ball joint ass'y					
25-B	60-721	Looper drive lever and link ass'y					
25-C	60-128	Looper avoid connection ass'y					
25-D	60-323	Looper avoid link ass'y					

From the library of: Diamond Needle Corp



## 6. Feed rocker (送り台機構)

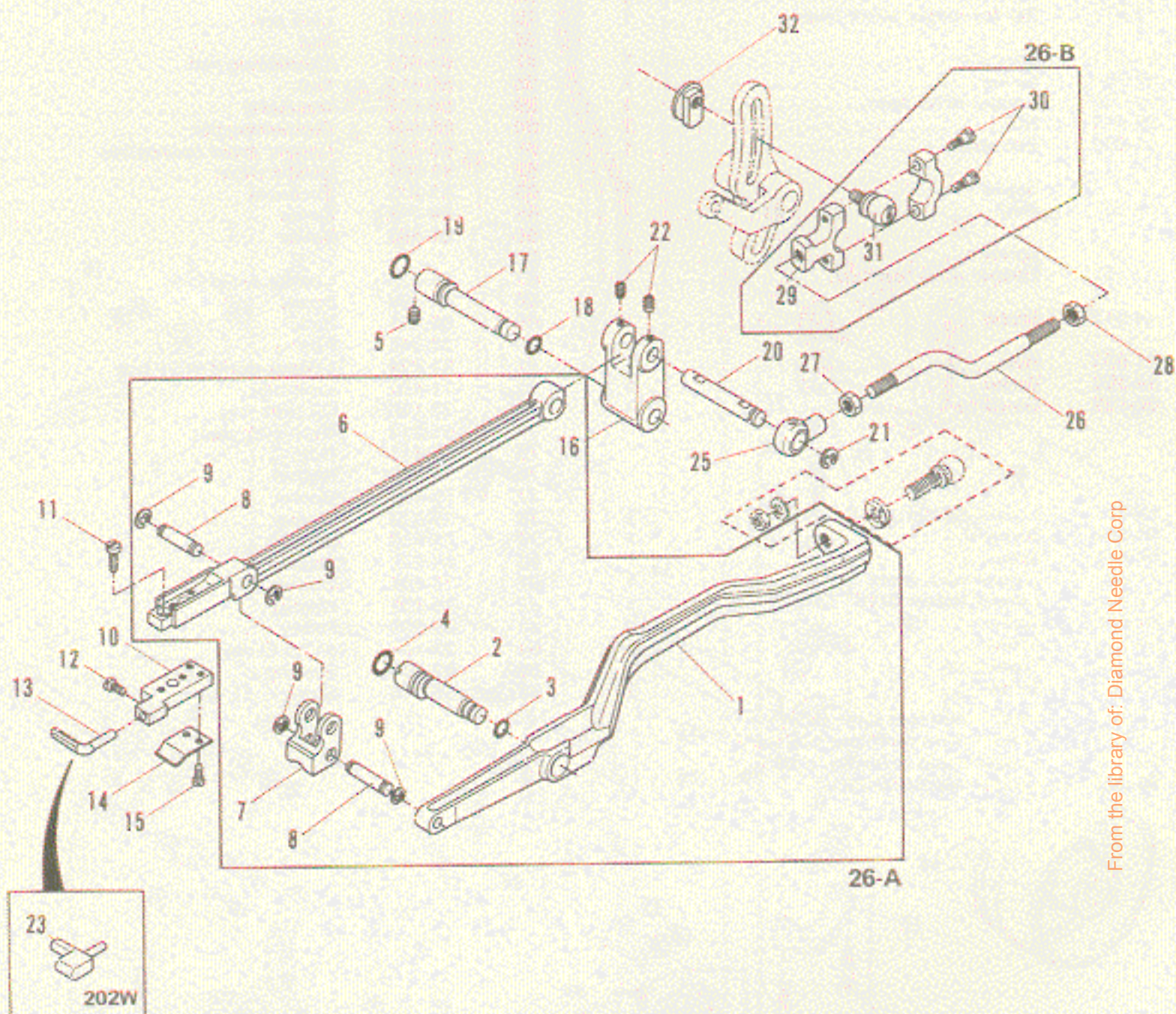

From the library of: Diamond Needle Corp

Ref. No.	Part No.	Part Name	Q'ty	Ref. No.	Part No.	Part Name	Q'ty
1	51-202	Feed rocker arm	1	17	51-212	Feed shaft	1
2	51-205	Feed bar adjusting pin	1	18	23-189	O-ring	1
3	23-186	O-ring	1	19	23-185	O-ring	1
4	23-18P	O-ring	1	20	55-221	Feed bar shaft	1
5	84-521	Screw	2	21	93-211	Retaining ring	1
6	55-253	Feed bar	1	22	84-161	Screw	2
7	55-203	Feed bar guide	1	23	18-222	Needle guard (202W)	1
8	51-204	Link pin	2	24			
9	93-201	Retaining ring	4	25	63-401	Connecting	1
10	18-213	Needle guard holder	1	26	51-223	Feed adjusting connection	1
11	84-362	Screw	2	27	86-411	Nut	1
12	84-364	Screw	1	28	86-412	Nut (left)	1
13	18-212	Needle guard	1	29	63-812	Ball joint	1
14	51-254	Spring	1	30	84-572	Screw	2
15	85-611	Screw	2	31	61-832	Feed rocker driving connecting ball	1
16	55-241	Feed rocker	1	32	51-222	Adjusting nut	1
26-A	50-521	Feed bar ass'y					
26-B	60-322	Feed rocker driving connecting rod ass'y					



# 7. Foot lifter mechanism (押え上げ機構)

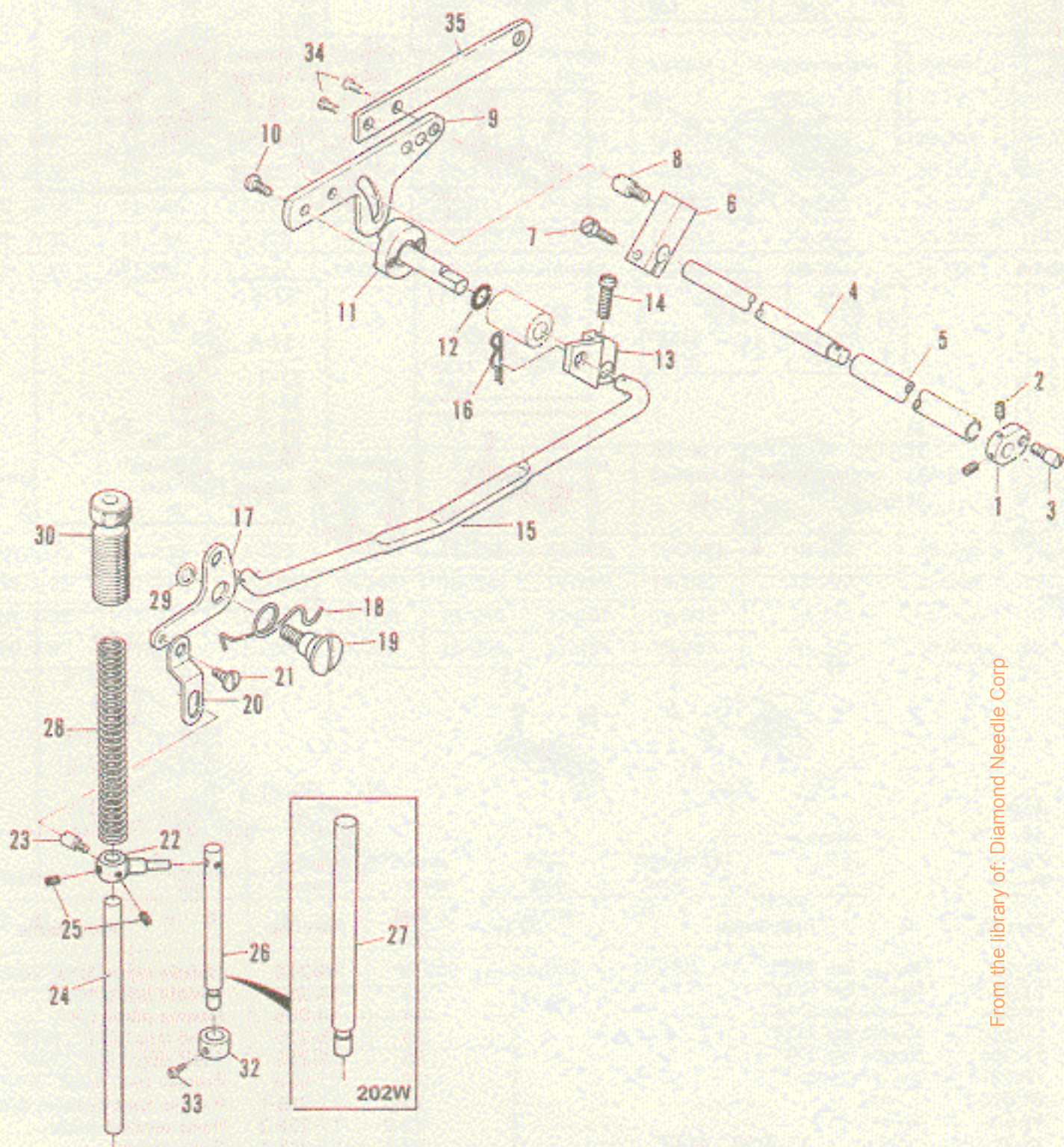

From the library of: Diamond Needle Corp

Ref. No.	Part No.	Part Name	Q'ty	Ref. No.	Part No.	Part Name	Q'ty
1	77-101	Lifter lever connecting	1	19	84-781	Screw	1
2	84-512	Screw	2	20	77-131	Lifter lever link	1
3	84-562	Screw	1	21	84-581	Screw	1
4	77-111	Foot lifter crankshaft B	1	22	77-128	Presser bar connection	1
5	77-121	Crankshaft pipe	1	23	84-561	Screw	1
6	77-103	Adjusting post supporter	1	24	71-523	Presser guide bar	1
7	84-812	Screw	1	25	84-511	Screw	2
8	84-561	Screw	1	26	71-546	Presser bar	1
9	77-145	Presser foot lifter lever	1	27	71-550	Presser bar C (202W)	1
10	84-566	Screw	2	28	79-121	Presser bar spring	1
11	77-115	Presser foot lifter lever post	1	29	75-453	Washer	1
12	23-189	O-ring	1	30	85-762	Screw	1
13	77-107	Presser foot lifter connecting plate	1	31			
14	84-764	Screw	1	32	75-154	Collar	1
15	77-120	Lifter lever connecting bar	1	33	84-161	Screw	1
16	93-611	Snap pin A	1	34	84-763	Screw	2
17	77-109	Lifter lever spring supporter	1	35	77-129	Presser foot lifter plate	1
18	79-221	Lifter lever spring	1	36			



# 8. Gauge parts (ゲージ関係)

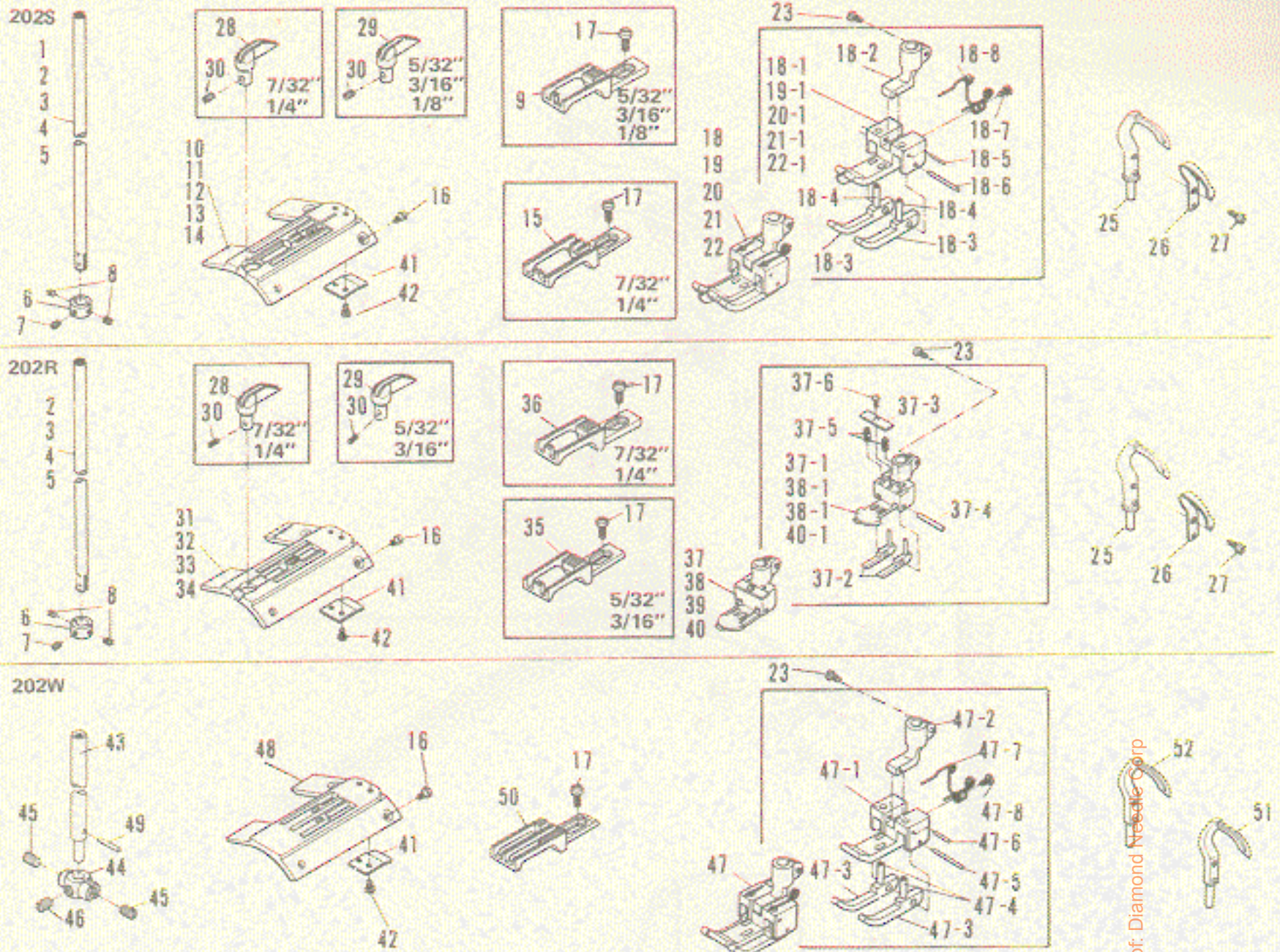

Ref. No.	Part No.	Part Name	Q'ty	Ref. No.	Part No.	Part Name	Q'ty
1	11-224	Needle bar 1/8"	1	32	14-245	Needle plate 3/16"	1
2	11-234	Needle bar 5/32"	1	33	14-255	Needle plate 7/32"	1
3	11-244	Needle bar 3/16"	1	34	14-265	Needle plate 1/4"	1
4	11-254	Needle bar 7/32"	1	35	15-235	Feed dog 5/32", 3/16"	1
5	11-264	Needle bar 1/4"	1	36	15-255	Feed dog 7/32", 1/4"	1
6	12-225	Needle clamp	1	37	17-235	Presser foot 5/32" 3/16"	1
7	84-513	Screw	1	37-1	17-235-1	Presser foot bottom 5/32"	1
8	84-511	Screw	2	37-2	17-235-2	Feed section guide	2
9	15-213	Feed dog 1/8", 3/16", 5/32"	1	37-3	17-235-3	Spring plate	1
10	14-224	Needle plate 1/8"	1	37-4	17-235-4	Pin	1
11	14-234	Needle plate 5/32"	1	37-5	17-235-5	Spring	2
12	14-244	Needle plate 3/16"	1	37-1		Presser foot bottom 5/32"	1
13	14-254	Needle plate 7/32"	1	37-2		Feed section guide	2
14	14-264	Needle plate 1/4"	1	37-3		Pin	1
15	15-211	Feed dog 1/4", 7/32"	1	37-4		Spring	2
16	84-464	Screw	2	37-5		Spring plate	1
17	84-571	Screw	1	37-6	85-623	Screw	1
18	17-224	Presser foot 1/8"	1	38	17-245	Presser foot 3/16"	1
18-1	17-224-1	Presser foot bottom 1/8"	1	38-1		Presser foot bottom 3/16"	1
18-2	17-224-2	Presser foot shank	1	39	17-255	Presser foot 7/32"	1
18-3	17-224-3	Feed section guide	2	39-1		Presser foot bottom 7/32"	1
18-4	17-224-4	Pin	2	40	17-265	Presser foot 1/4"	1
18-5		Pin	1	40-1		Presser foot bottom 1/4"	1
18-6		Pin	1	41	51-254	Spring	1
18-7	84-161	Screw	1	42	85-611	Screw	2
18-8	17-224-5	Spring	1	43	11-501	Needle bar	1
19	17-234	Presser foot 5/32"	1	44	12-202	Needle holder 5/16"	1
19-1		Presser foot bottom 5/32"	1	45	84-712	Screw	2
20	17-244	Presser foot 3/16"	1	46	84-717	Screw	1
20-1		Presser foot bottom 5/32"	1	47	17-202	Presser foot 5/16"	1
21	17-254	Presser foot 7/32"	1	47-1	17-202-1	Presser foot bottom 5/16"	1
21-1		Presser foot bottom 7/32"	1	47-2	17-202-2	Presser foot shank	1
22	17-264	Presser foot 1/4"	1	47-3	17-202-3	Feed section guide	2
22-1		Presser foot bottom 1/4"	1	47-4	17-202-4		
23	84-382	Screw	1	47-5	17-202-5	Knock pin	1
24				47-6	17-202-6	Hinge pin	1
25	19-202	Looper	1	47-7	17-202-7	Spring	1
26	18-202	Looper needle guard	1	47-8	84-161	Screw	1
27	85-622	Screw	1	48	14-202	Needle plate 5/16"	1
28	25-209	Guide D 7/32", 1/4"	1	49	71-206	Knock pin for needle bar	1
29	25-208	Guide C 1/8", 5/32", 3/16"	1	50	15-202	Feed dog	1
30	84-311	Screw	1	51	19-206	Looper (front)	1
31	14-235	Needle plate 5/32"	1	52	19-207	Looper (rear)	1

From the library of: Diamond Needle Corp



## 9. Gauge list (ゲージ・パーツ、一覧表)

### DVC-202S

No.	Model 機種	Needle bar 針棒	Needle holder 針株	Needle plate 針板	Feed dog 送り歯	Presser foot 押え	Looper ルーバー	Looper guard 補助ルーバー	Guide ガイド	Looper holder ルーバー台	Needle guard 針受け
1	DVC-202S 1/8"	11-224	12-225	14-224	15-211	17-224	19-202	18-202	25-208	19-321	18-212
2	DVC-202S 5/32"	11-234	12-225	14-234	15-211	17-234	19-202	18-202	25-208	19-321	18-212
3	DVC-202S 3/16"	11-244	12-225	14-244	15-211	17-244	19-202	18-202	25-208	19-321	18-212
4	DVC-202S 7/32"	11-254	12-225	14-254	15-213	17-254	19-202	18-202	25-209	19-321	18-212
5	DVC-202S 1/4"	11-264	12-225	14-264	15-213	17-264	19-202	18-202	25-209	19-321	18-212

### DVC-202R

No.	Model 機種	Needle bar 針棒	Needle holder 針株	Needle plate 針板	Feed dog 送り歯	Presser foot 押え	Looper ルーバー	Looper guard 補助ルーバー	Guide ガイド	Looper holder ルーバー台	Needle guard 針受け
1	DVC-202R 5/32"	11-235	12-225	14-235	15-235	17-235	19-202	18-202	25-208	19-321	18-212
2	DVC-202R 3/16"	11-245	12-225	14-245	15-235	17-245	19-202	18-202	25-208	19-321	18-212
3	DVC-202R 7/32"	11-255	12-225	14-255	15-255	17-255	19-202	18-202	25-209	19-321	18-212
4	DVC-202R 1/4"	11-265	12-225	14-265	15-255	17-265	19-202	18-202	25-209	19-321	18-212

### DVC-202W

No.	Model 機種	Needle bar 針棒	Needle holder 針株	Needle plate 針板	Feed dog 送り歯	Presser foot 押え	Looper ルーバー		Looper holder ルーバー台	Needle guard 針受け
							front 前	rear 後		
1	DVC-202W 5/16"	11-501	12-202	14-202	15-202	17-202	19-206	19-207	19-322	18-222
2										
3										



# 10. Accessories (アクセサリ)

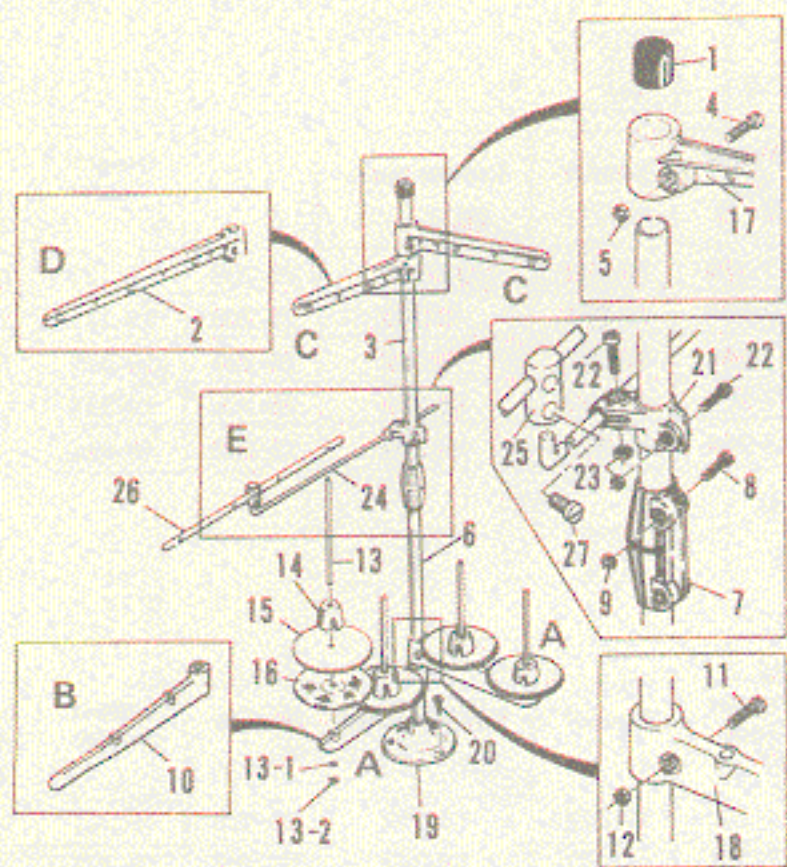

DVC-202S, 202R

DVC-202W

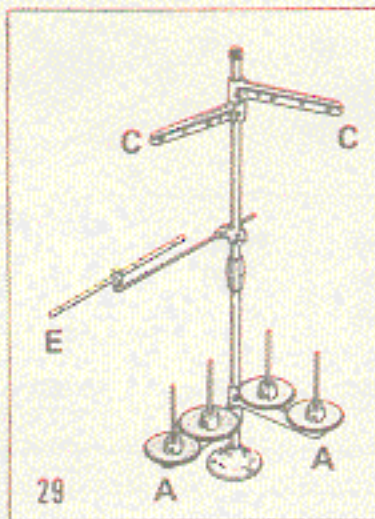
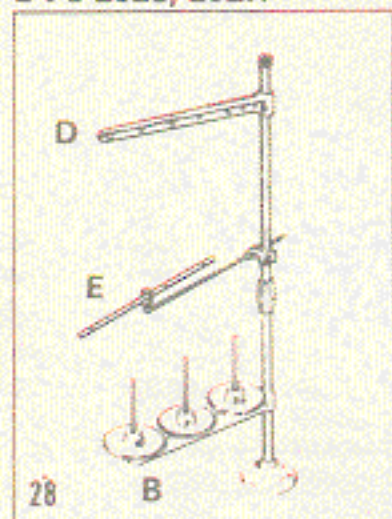

CS-3D

CS-4D

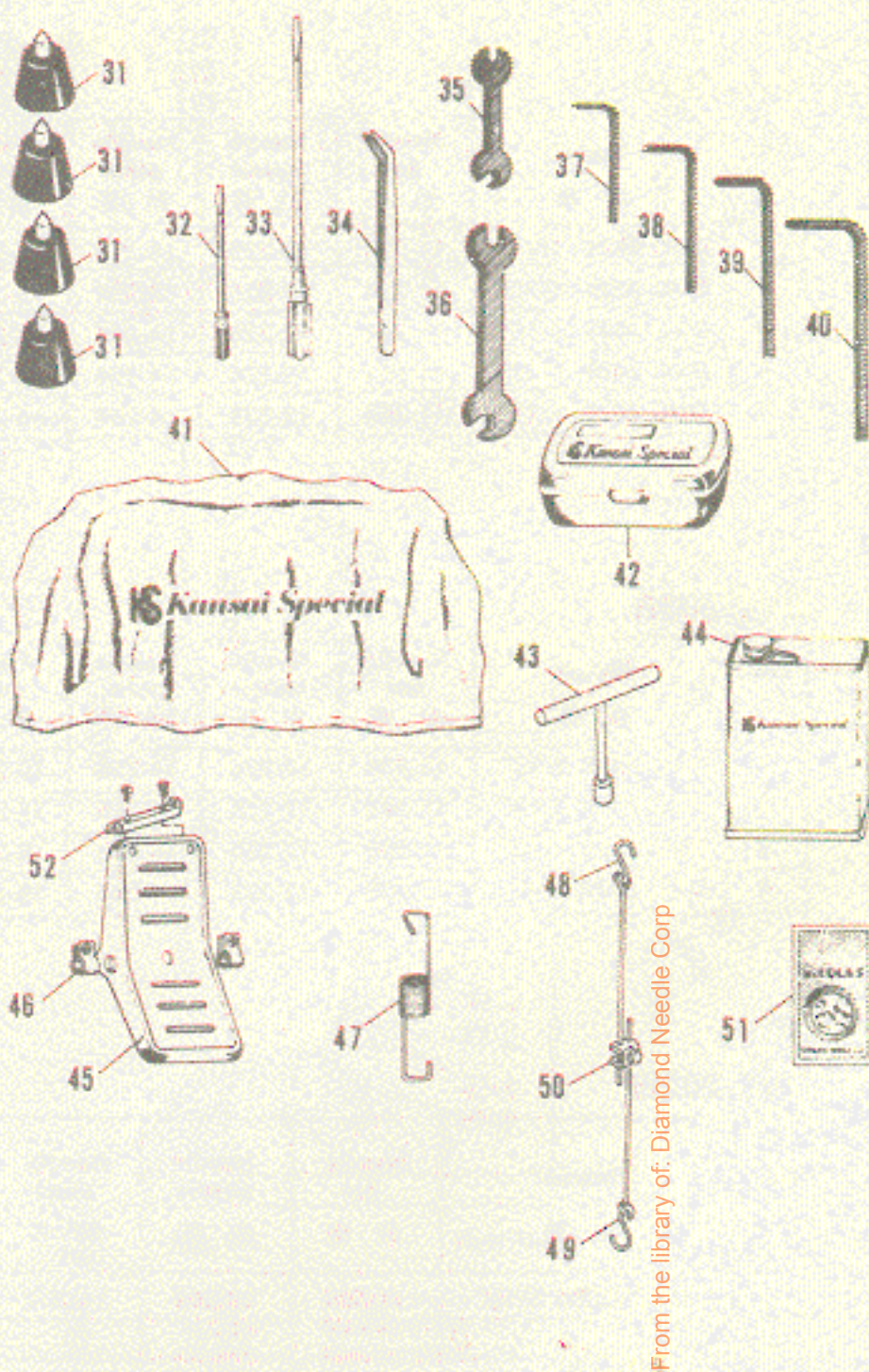

From the library of: Diamond Needle Corp

Ref. No.	Part No.	Part Name	Q'ty
1	42-120	Cap	1
2	42-116	Thread guide bracket (3)	1
3	42-113	Bar (upper)	1
4		Screw	1
5		Nut	1
6	42-112	Bar (lower)	1
7		Joint	1
8		Screw	1
9		Nut	1
10	42-115	Spool pin bracket (3)	1
11		Screw	1
12		Nut	1
13	42-117	Spool pin	3
13-1		Washer	3
13-2		Screw	3
14	42-118	Spool retaining fin	3
15	42-119	Spool mat	3
16	42-123	Spool tray	3
17		Tread guide bracket (2)	2
18		Spool pin bracket (2)	2
19	42-111	Base	1
20	42-122	Screw	3
21		Shank	1
22		Screw	2
23		Nut	2
24			
25		Thread eyelet guide	1

Ref. No.	Part No.	Part Name	Q'ty
26		Thread eyelet guide	1
27		Screw	2
28	40-003	Thread stand CS-3D	1 set
29	40-004	Thread stand CS-4D	1 set
30			
31	31-162	Joint	1
32	28-451	Screwdriver (small)	1
33	28-452	Screwdriver (large)	1
34	28-011	Tweezers	1
35	28-421	Spanner (small)	1
36	28-422	Spanner (large)	1
37	28-311	Wrench A	1
38	28-312	Wrench B	1
39	28-313	Wrench C	1
40	28-314	Wrench D	1
41	28-021	Machine cover	1
42	28-001	Accessory box	1
43	28-464	Wrench T	1
44	28-611	Oil TELLESO 33	1
45	77-001	Pedal	1
46	77-002	Pedal stopper	2
47	77-003	Spring	1
48	77-006	Tie-rod (upper)	1
49	77-007	Tie-rod (lower)	1
50	77-005	Joint (with screw)	1
51	13-	DV x43, 62x43, SY3516, UY3516.	
52	77-004	Coupling	1



# 11. Table stand installation diagram (テーブルスタンド据付図)

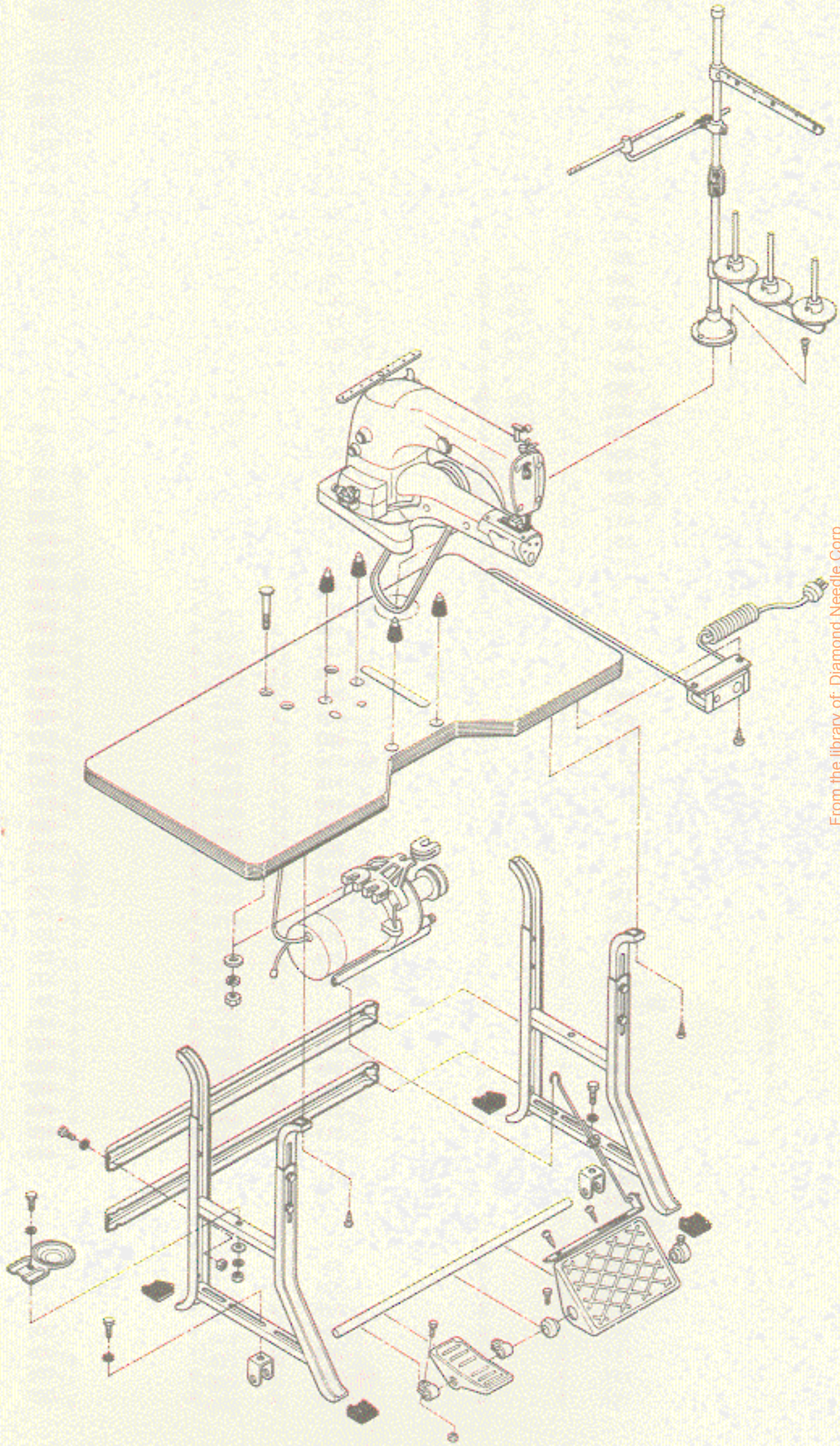

From the library of: Diamond Needle Corp



# 12. Index (索引)

Part No.	Q'ty	Page No.	Part No.	Q'ty	Page No.	Part No.	Q'ty	Page No.	Part No.	Q'ty	Page No.
11-224	1	11	23-190	1	8	41-112	1	4	55-241	1	9
-234	1	11	-195	1	6	-115	1	4	-253	1	9
-244	1	11	-195	1	6	-115	2	4	61-211	1	8
-254	1	11	-197	1	4	-117	1	4	-521	1	8
-264	1	11	-197	1	8	-117	2	4	-726	1	6
-501	1	11	-204	1	2	-131	1	4	-831	1	8
12-202	1	11	-214	1	2	-131	2	4	-832	1	9
-225	1	11	-226	1	2	-132	1	4	-836	1	8
13-		13	-227	1	2	-172	1	4	-837	1	8
14-202	1	11	-232	1	2	-172	2	4	63-321	1	8
-224	1	11	-242	1	5	-303	1	4	-361	1	8
-234	1	11	-246	1	2	-316	1	2	-401	1	8
-235	1	11	-260	1	6	-317	1	2	-401	1	9
-244	1	11	-298	1	2	-701	2	4	-521	1	8
-245	1	11	-300	1	2	-702	1	4	-711	1	6
-254	1	11	-324	3	4	-721	1	4	-805	1	8
-255	1	11	-341	2	6	42-003	1 set	13	-812	1	9
-264	1	11	-341	1	8	-111	1	13	65-504	1	8
-265	1	11	-353	1	5	-112	1	13	66-111	1	6
15-202	1	11	25-202	1	2	-113	1	13	67-156	1	8
-211	1	11	-203	1	2	-115	1	13	-157	1	8
-213	1	11	-208	1	11	-116	1	13	69-103	1	6
-235	1	11	-209	1	11	-117	3	13	-125	1	8
-255	1	11	28-001	1	13	-118	3	13	-208	1	8
17-202	1	11	-011	1	13	-119	3	13	-304	1	5
-224	1	11	-021	1	13	-120	1	13	-351	1	6
-234	1	11	-311	1	13	-122	3	13	71-206	1	11
-235	1	11	-312	1	13	-123	3	13	-246	1	2
-244	1	11	-313	1	13	43-102	1	4	-261	1	2
-245	1	11	-314	1	13	-106	1	4	-432	1	6
-254	1	11	-421	1	13	-111	1	4	-432	1	8
-255	1	11	-422	1	13	-112	1	4	-482	1	2
-264	1	11	-451	1	13	-303	1	4	-550	1	10
-265	1	11	-452	1	13	-401	1	4	-523	1	10
18-202	1	11	-464	1	13	-402	2	4	-546	1	10
-212	1	9	-611	1	13	45-110	1	4	-547	1	8
-213	1	9	31-162	4	13	-118	1	4	-671	1	8
-222	1	9	35-151	1	5	-140	1	4	-824	1	8
19-202	1	11	-154	1	5	-142	1	4	-932	1	6
-206	1	11	-155	1	5	-202	1	2	73-113	1	6
-207	1	11	-156	1	5	-216	1	2	75-132	1	8
-321	1	8	-157	1	5	-226	1	4	-154	1	10
-322	1	8	-160	1	2	47-207	1	4	-321	1	8
21-146	1	2	-161	1	5	-211	1	4	-332	2	6
-147	1	2	-268	1	5	-212	1	4	-372	1	8
-205	1	2	39-107	1	6	49-135	1	4	-381	1	4
-222	1	2	-124	1	2	51-201	1	8	-401	1	8
-326	1	2	-141	1	2	-202	1	9	-452	1	8
-406	1	2	-148	1	2	-204	2	9	-453	1	4
-407	1	2	-171	1	2	-205	1	9	-453	2	4
-446	1	2	-172	1	2	-211	1	8	-453	1	8
-451	1	2	-214	1	2	-211	1	8	-453	1	8
-516	1	2	40-003	1	13	-212	1	9	-453	1	10
22-201	1	2	-004	1	13	-213	1	8	-456	1	4
-212	1	2	41-101	1	4	-214	1	8	-458	1	2
-221	1	2	-101	2	4	-221	1	8	-468	1	4
23-171	1	2	-105	1	4	-222	1	9	77-001	1	13
-185	1	9	-105	2	4	-223	1	9	-002	1	13
-186	1	9	-107	1	4	-224	1	8	-003	1	13
-188	1	8	-107	2	4	-225	1	8	-004	1	13
-188	1	9	-111	2	4	-254	1	9	-005	1	13
-189	1	2	-111	4	4	-254	1	11	-006	1	13
-189	1	9	-112	1	4	55-203	1	9	-007	1	13
-189	1	10				-221	1	9			

From the library of Diamond Needle Corp.



## 12. Index (索引)

Part No.	Q'ty	Page No.	Part No.	Q'ty	Page No.	Part No.	Q'ty	Page No.
77-101	1	10	84-512	2	10	85-762	1	10
-103	1	10	-513	1	11	86-411	1	4
-107	1	10	-521	1	4	-411	2	4
-109	1	10	-521	1	8	-411	1	8
-111	1	10	-521	1	8	-411	1	8
-115	1	10	-521	2	9	-411	1	8
-120	1	10	-531	1	2	-411	2	8
-121	1	10	-561	1	10	-411	1	9
-128	1	10	-561	1	10	-412	1	9
-129	1	10	-562	1	10	-413	1	8
-131	1	10	-564	1	8	-413	3	8
-145	1	10	-566	2	2	-415	1	8
79-121	1	10	-566	5	2	-742	1	6
-221	1	10	-566	4	5	87-511	1	2
-506	1	2	-566	2	10	-661	4	2
			-567	2	6	-661	4	2
81-113	1	6	-568	1	5	-812	1	2
-116	1	5	-568	2	6			
-119	1	5	-568	2	8	91-301	1	8
-145	1	5	-568	2	8	-303	1	8
-152	1	5	-568	2	8	-306	1	6
-156	1	5	-571	1	2	92-231	1	8
-157	1	5	-571	1	2	93-201	4	9
-158	1	5	-571	2	2	-211	1	9
-161	1	5	-571	2	2	-611	1	10
-184	1	5	-571	4	2	-701	4	2
-185	1	5	-571	1	4	94-211	1	5
-255	1	5	-571	2	4	-221	1	5
-405	1	5	-571	1	11	-236	1	5
-411	1	6	-572	1	6			
84-112	1	8	-572	2	8			
-161	1	2	-572	2	9			
-161	2	2	-575	1	4			
-161	2	4	-577	1	2			
-161	1	11	-580	2	2			
-161	2	9	-581	1	10			
-161	1	10	-616	1	8			
-161	1	11	-616	2	8			
			-664	4	2			
-162	1	2	-711	2	4			
-162	1	5	-712	2	11			
-162	2	4	-717	1	11			
-163	1	2	-718	2	8			
-171	1	4	-718	2	8			
-311	1	11	-761	1	2			
-361	1	2	-761	1	8			
-361	1	4	-761	1	8			
-361	1	4	-763	1	8			
-361	2	5	-763	2	10			
-362	2	9	-764	1	4			
-363	1	4	-764	2	6			
-363	1	4	-764	1	10			
-363	1	8	-781	1	10			
-364	1	4	-812	1	10			
-364	1	9	85-114	2	8			
-365	1	6	-182	1	6			
-365	1	8	-211	1	6			
-366	1	6	-521		2			
-367	4	8	-522	1	5			
-374	1	4	-531	1	4			
-382	1	11	-611	2	9			
-464	2	11	-611	1	11			
-511	2	10	-621	2	4			
-511	2	11	-622	1	11			
-512	1	8	-623	1	11			

From the library of: Diamond Needle Corp